

BINDERY GUIDE

BINDERY & FINISHING DESCRIPTIONS

PERFECT BOUND

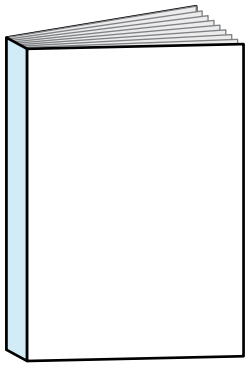

Folded pages are glued together using a flexible adhesive at the spine. Paper is then wrapped around the front and back cover leaving you with a high-end finished product and opportunity for a printed spine.

Commonly used for catalogs, paperbacks and magazines.

FOLDING & SCORING

Scoring is the process of making a line or depression in paper so it will fold easier. Scoring helps to avoid cracking and to create a crisp, strong fold, especially in thicker paper stocks and materials with full ink coverage.

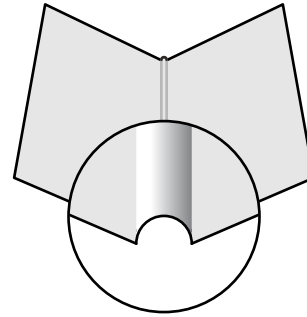

SADDLE STITCHED

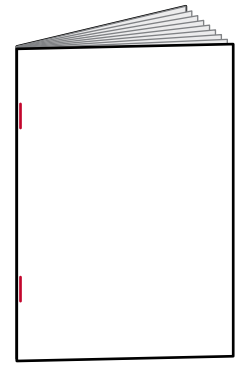

Saddle stitching is a cost-effective and fast option that is perfect for small booklets. Pages are nested together and wire stapled or stitched along the crease of the fold.

Great for brochures, pamphlets and small books with fewer than 100 pages.

SPIRAL BINDING

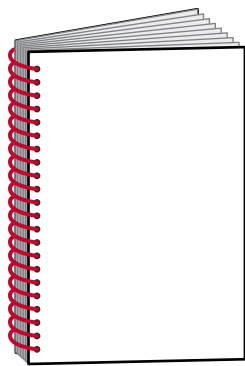

A low-cost binding method that uses a machine to push a hole pattern through loose pages. A spiral coil made from plastic or wire is then threaded through the holes along one side of the printed piece. Coils come in a variety of color options.

Excellent for materials that you want to lay flat or have fold under itself.

COMB BINDING

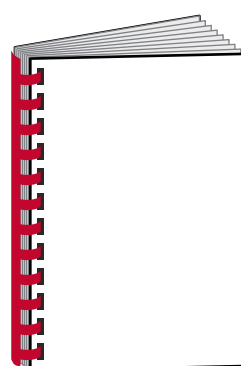

This cost-effective method uses a machine to punch holes through loose pages. A plastic or wire comb is then inserted into the holes along one edge of the printed piece. Combs come in a variety of colors.

Great for thicker publications and can easily be edited if pages need to be added or removed.

CASE BOUND

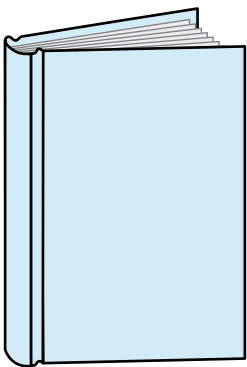

Case bound is the most durable and highest quality binding method. The pages must be first sewn or perfect bound and then they are encased with a hard or soft cover. Cases can be made from leather, cloth or paper to add a personal touch to your publication.

Perfect for books, cookbooks and textbooks.

LAY FLAT

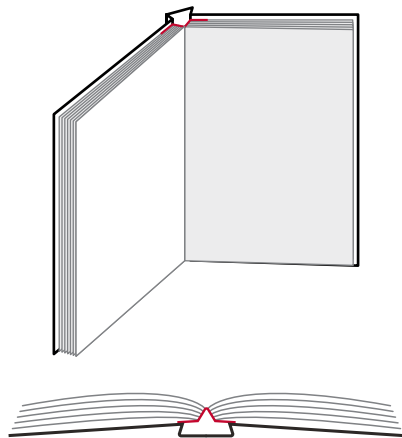

Lay-flat binding is a process that allows the pages to lie fully open. The cover is glued only to the sides of the spine, allowing the pages to float above the spine's cover when opened.

Perfect for publications that you want to be more reader friendly, such as cookbooks, photo books, manuals, and textbooks.

SWISS BOUND

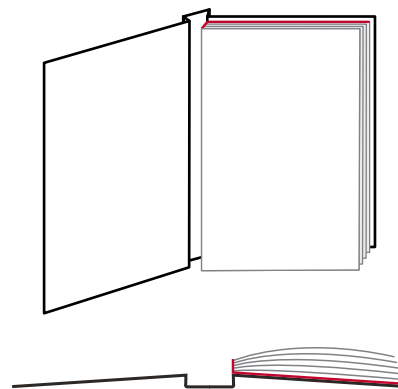

Swiss bound is the method of mounting the text block, usually smyth sewn or perfect bound, to the inside back cover of a hard case. The spine is left free and visible and generally covered with paper, cloth or leather to add beauty, functionality and durability to the printed piece.

This process allows the spine to lay flat and creates an upscale and high-end look.

SQUARE BACK

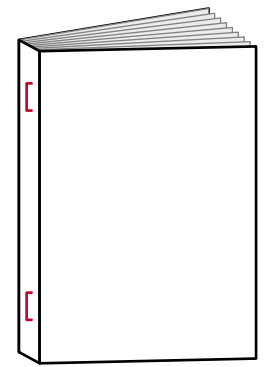

Square back books are saddle-stitched, but then squashed at the spine to create a square edge. This gives the appearance of a perfect bound book, with a sharp edge, but at a lower price point.

As with saddle stitching, square back has thickness limitations of approx. 24-200 pages.

TAPE BOUND

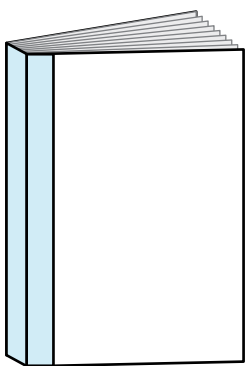

Tape binding uses strips of tape or cloth that are coated with glue. The strips are wrapped around the spine and front and back cover of the book. The tape is available in a variety of colors.

Tape binding is very durable and has the ability to lay flat.

SCREW BOUND

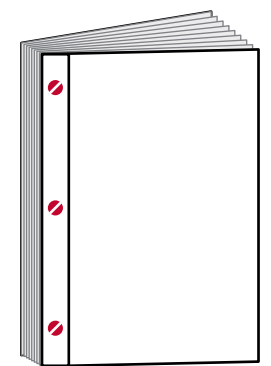

Screw binding involves first drilling holes through both the block of pages and cover. They are then secured together with metal screws, often referred to as Chicago screws.

This method creates an incredibly strong bind and is ideal for thick documents.

For more information on bindery options contact your B&B rep today.

BB PRINT SOURCE
• BE IMPRESSED •